

DATE	NO	SIGN	REVISION	REMARKS
------	----	------	----------	---------

PORA ELECTRIC MACHINERY CO.,LTD.

ALL RIGHTS HELD BY PORA ELECTRIC MACHINERY CO.,LTD. INCLUDING APPLICATIONS FOR PATENTS AND PROPERTY RIGHTS AND THE RIGHTS OF DISPOSAL SUCH AS TO REPRODUCE ON TO THIRD PARTIES.

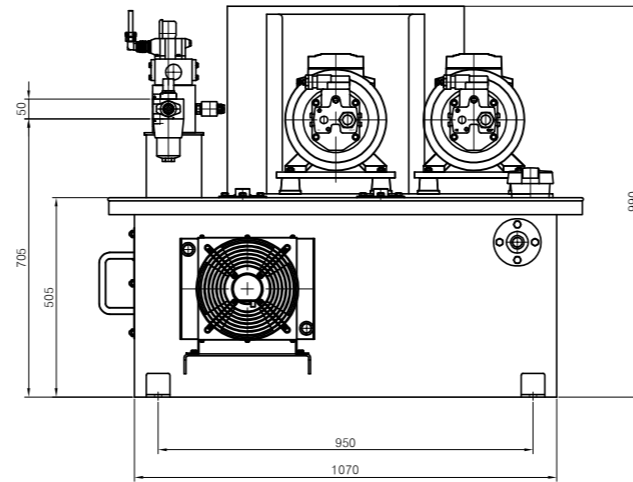
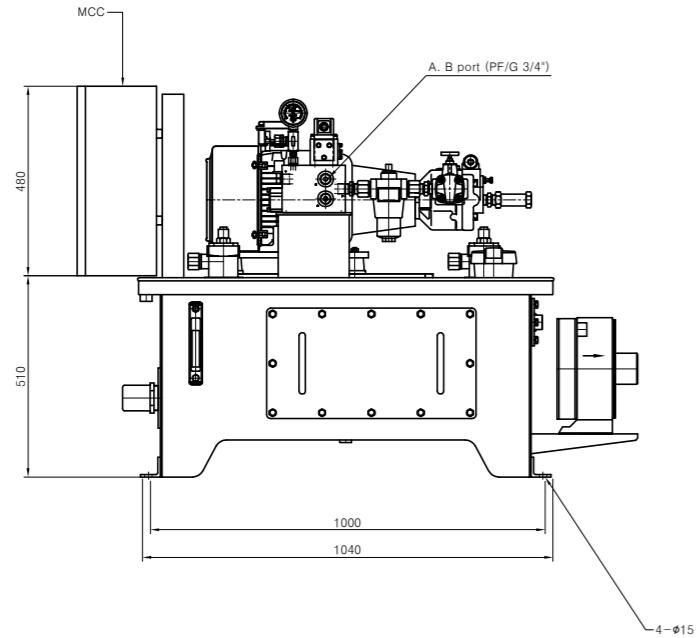
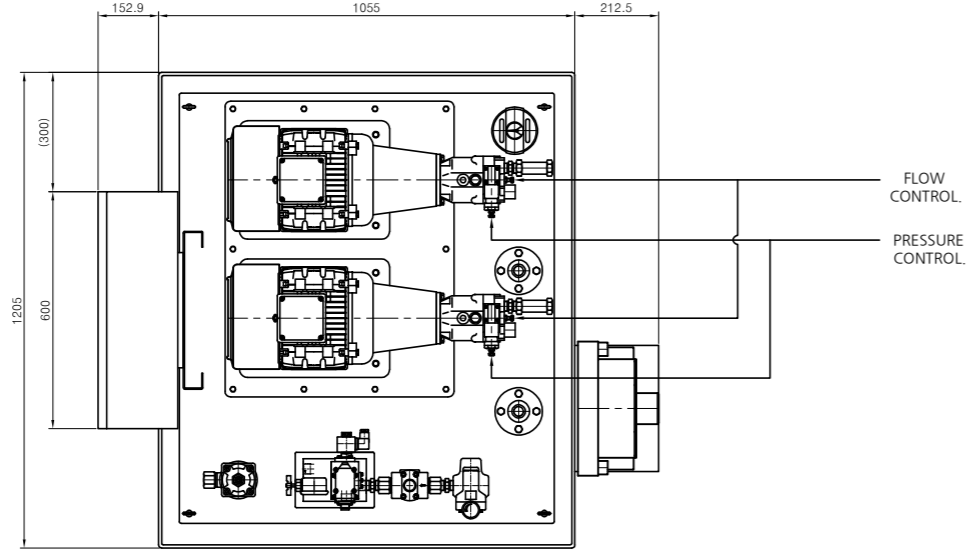

Specifications

Model	PR-TD3S-5.5-4-22-200-FHMN-386-22S
Motor power input	5.5Kw*4P * 2 ea
Sol. valve power input	1Φ-220Vac
Oil fan cooler power input	
Max. pressure	100 Bar
Pump capacity	30L / min
Tank oil volume	200L
Oil number	ISO-VG-46
Power input	3Φ-380Vac / 60Hz (6Kw*20A)
Ambient Temperature	-0℃ ~ +50℃
Weight	350 Kg

Hydronic Diagram

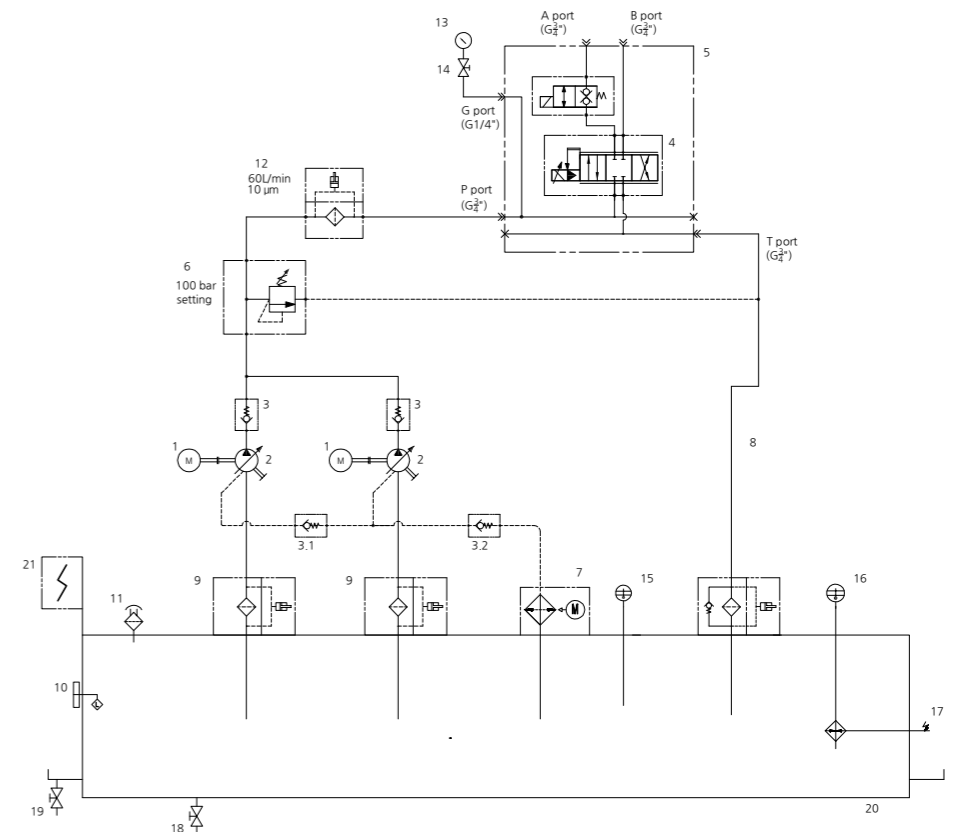

NO	ITEM	MAT'L	Q,TY	DIMENSION	REMARKS
DESIGN	CHECK	APPROVE	3D ANGLE	PR-TD3S-5.5-4-22-150-FHMN-000-22S	NAME OF ARTICLE Servo Hyd'power Tank Unit
KJHO	H.Y.M	-	SCALE 1 / 1		
22.03.08	22.03.10	-			
 PORA ELECTRIC MACHINERY CO.,LTD.				DWG NO.	EPC for Tension reel System - 04