

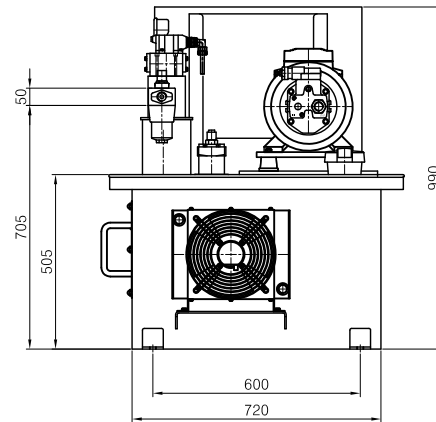

DATE	NO	SIGN	REVISION	REMARKS

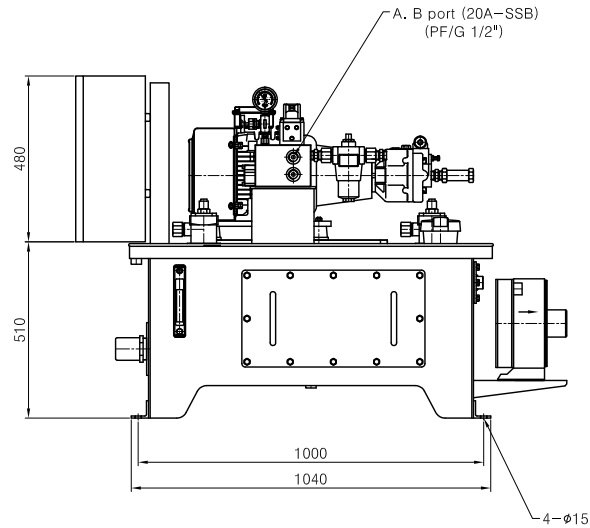
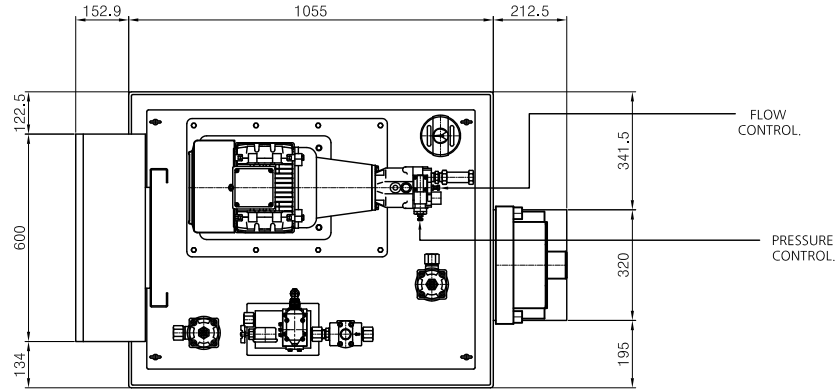
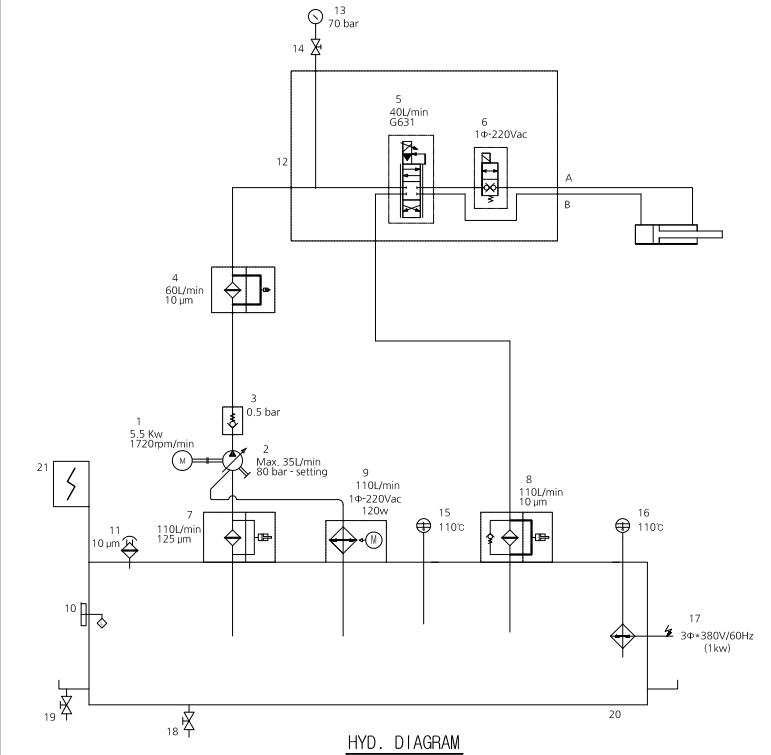

Specifications

Model	PR-TS3S-5.5-4-22-150-FHMN-386-22S
Motor power input	5.5Kw*4P
Sol. valve power input	1Φ-220Vac
Oil fan cooler power input	
Max. pressure	90 Kg/cm ²
Pump capacity	35L / min
Tank oil volume	150L
Oil number	ISO-VG-46
Power input	3Φ-380Vac / 60Hz - 7Kw
Ambient Temperature	0 ~ +50°
Weight	250 Kg



NO	ITEM	MAT'L	Q.TY	DIMENSION	REMARKS
DESIGN	CHECK	APPROVE	3D ANGLE	PR-TS3S-5.5-4-22-150-FHMN	Servo Hyd'power Tank Unit
H.Y.M	-	-	SCALE 1 / 1		
22.02.10	-	-	SCALE 1 / 1		
 PORA ELECTRIC MACHINERY CO., LTD.				DWG NO.	EPC for Tension reel System - 04