

DATE	NO	SIGN	REVISION	REMARKS
------	----	------	----------	---------

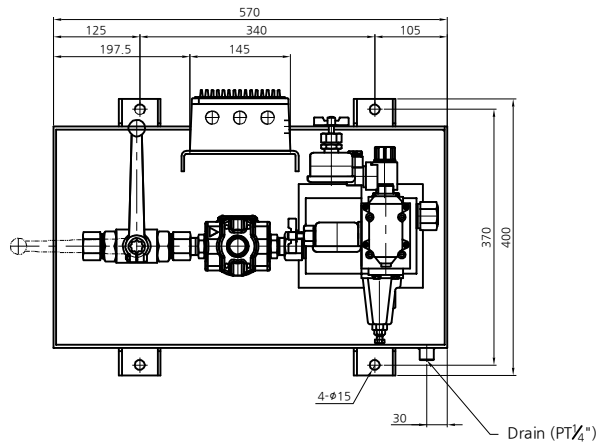

Terminal block arrangement					
SOL	SERVO	FILTER			
⊗	⊗	⊗	⊗	⊗	⊗

PORA Basic Coloration

Powder Coating
 Color : 5YR 5/5 (munsell color No.)
 Coating Thickness : 60 Micron over

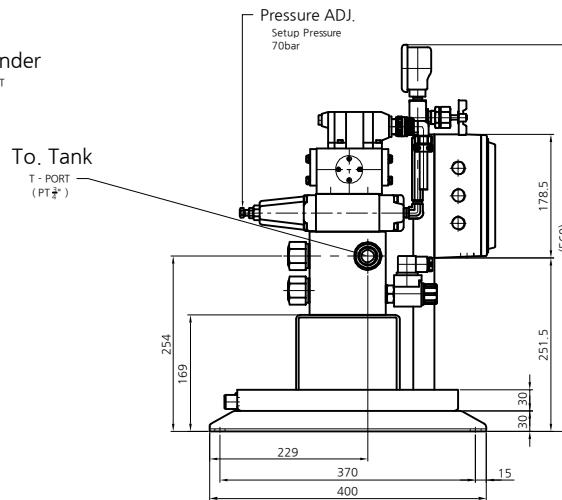
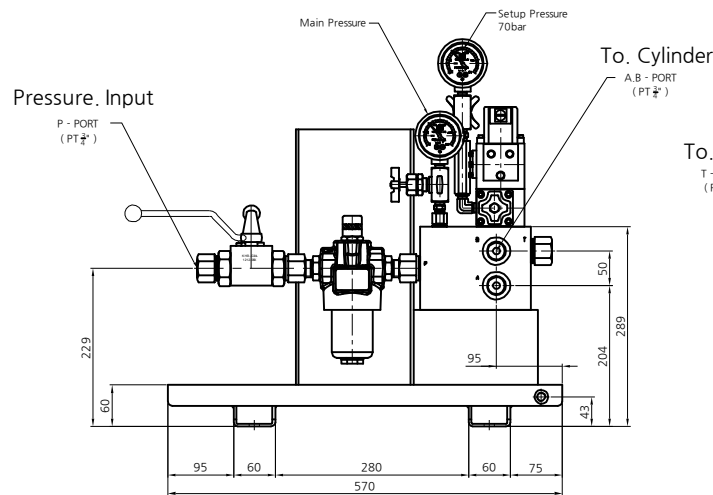

Specifications

MODEL	PR-SV-SM40-M60S-24	PR-SV-SM40-M60S-24	PR-SV-SM40-M60S-24
SOL. V/V VOLTAGE	24Vdc / 110Vac / 220Vac (Select)		
MAX.PRESSURE	Max. 210kg/cm ²		
SERVO VALVE CAPACITY	20 L/min	40 L/min	60 L/min
OIL NO.	ISO- VG46		
WEIGHT	50kg		

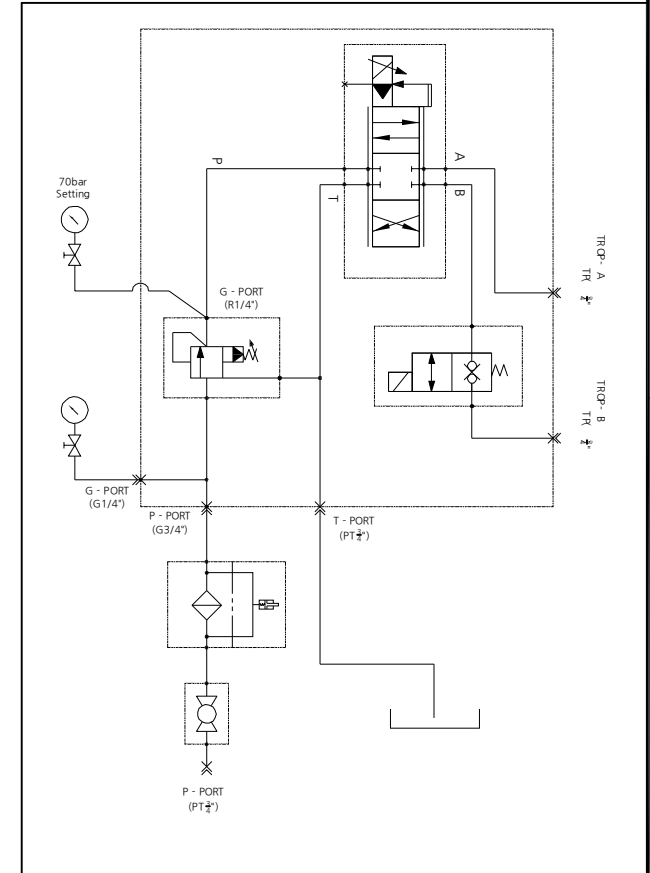

HYD. DIAGRAM

NO	ITEM	MAT'L	Q.TY	DIMENSION	REMARKS
DESIGN	CHECK	APPROVE	3D ANGLE	SERVO HYD'POWER GUIDE	
22.02.11	22.02.14		SCALE 1 / 1	PR-SV-SM40-M60S-24	
PORA ELECTRIC MACHINERY CO.,LTD.			DWG NO.	CPC for Pay off reel System-04	