

SPECIFICATIONS

Model	PR-HTD-11-4-37-350-F-N-M-S-440.50
Motor	11Kw*4P
Fan Cooler	220Vdc / 50Hz
Max.Pressure	max. 100 bar
Pump Capacity	50L / min
Tank oil volume	450L
Power input	3φ-440Vac / 50Hz - 11Kw
Ambient Temperature	0 ~ +60℃
Weight	450kg(EXLUDED OIL)

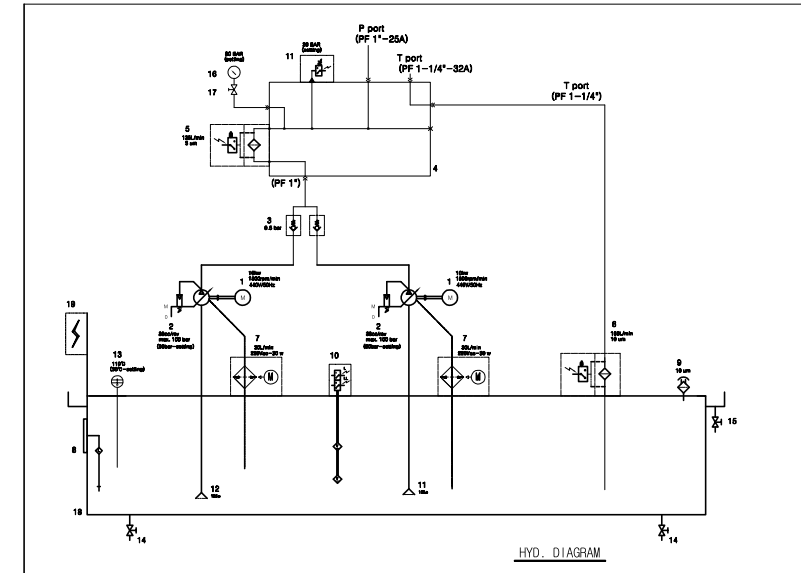

NO	ITEM	MAT'L	Q.TY	SIZE	REMARKS
DESIGN	CHECK	APPROVE	SCALE	MAME OF ARTICLE	PR-HTD-11-4-37-350-F-N-M-S-440.50
H.Y.M			1/1		SERVO HYD.POWER TANK UNIT
21.03.11					
PARA ELECTRIC MACHINERY CO., LTD.				DWGS NO	CPC for P.O.R + S.T - TANK