

DATE	NO	SIGN	REVISION	REMARKS

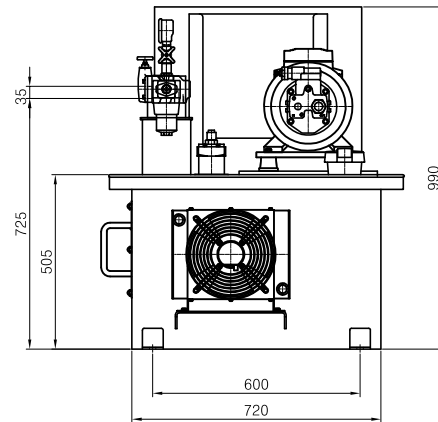
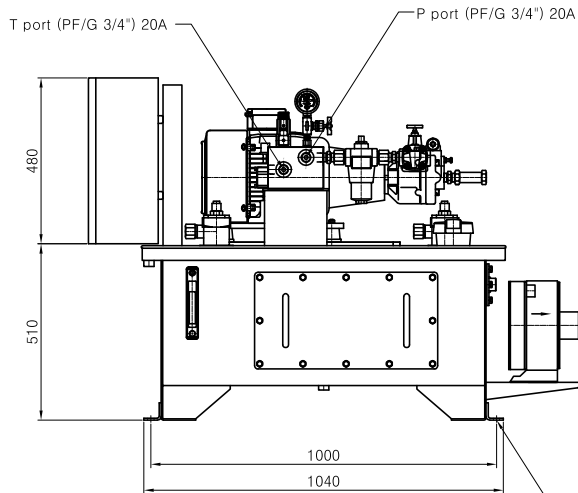
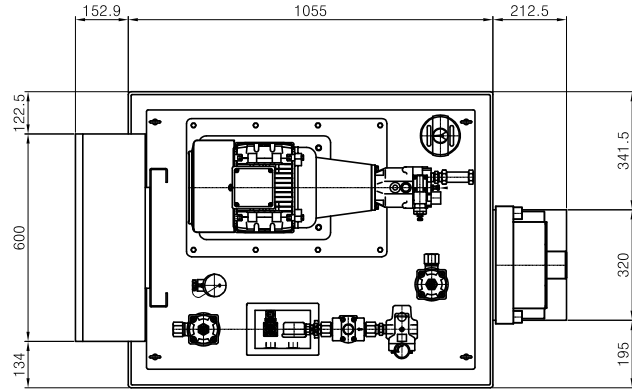

### Specifications

Model	PR-HTS-5.5-4-16-150-F-N-M-S-440.50
Motor power input	5.5Kw*4P
Oil fan cooler power input	1φ-220Vac / 50Hz
Max. pressure	100 Kg/cm <sup>2</sup>
Pump capacity	30L / min
Tank oil volume	150L
Oil number	ISO-VG-46
Power input	3φ-440Vac / 50Hz - 5.5Kw
Ambient Temperature	0 ~ +60℃
Weight	250 Kg

### Hydronic Diagram

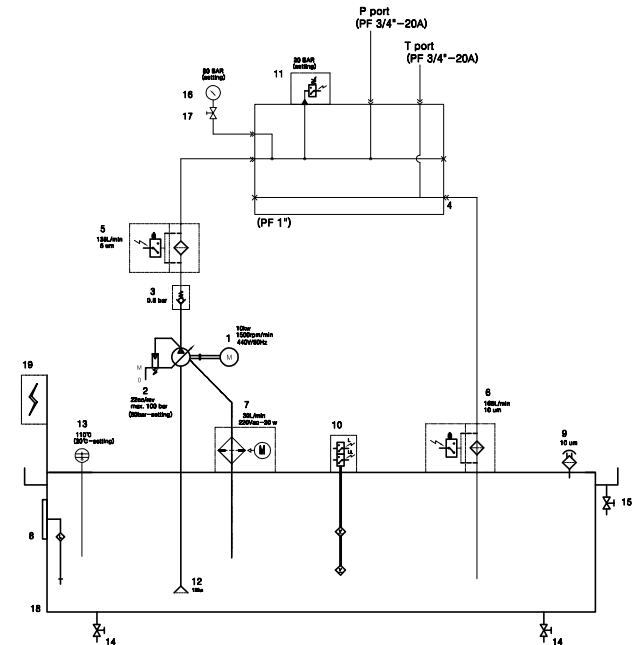

NO	ITEM	MAT'L	Q.TY	DIMENSION	REMARKS
DESIGN	CHECK	APPROVE	3D ANGLE	NAME OF ARTICLE	PR-HTS-5.5-4-16-150-F-N-M-S-440.50
H.Y.M	-	-	SCALE 1 / 1		Servo Hyd'power Tank Unit
21.03.11	-	-		DWG NO.	EPC for Tension reel Reel System CPC for Pay off Reel System