

DATE	NO	SIGN	REVISION	REMARKS

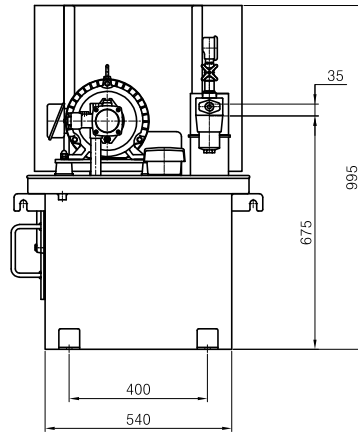
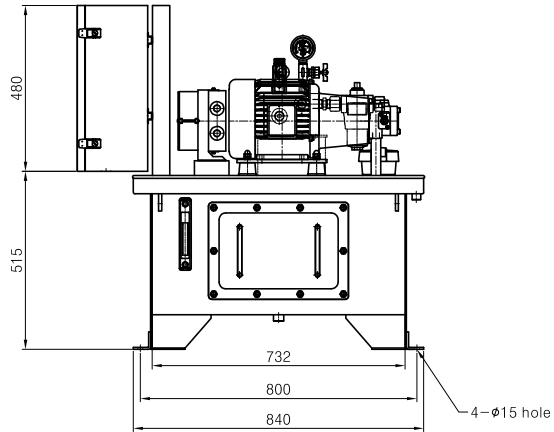
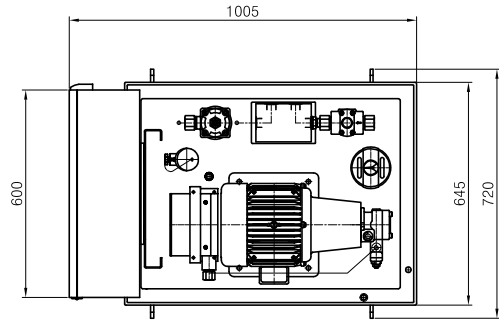

Specifications

Model	PR-HTS-2.2-4-8-100-F-N-M-S-440/50
Motor power input	2.2Kw*4P
Oil fan cooler power input	1Φ-220Vac / 50Hz
Max. pressure	70 Kg/cm ² (60 Kg/cm ² - Setting)
Pump capacity	12L / min
Tank oil volume	100L
Oil number	ISO-VG-46
Power input	3Φ-440Vac / 50Hz
Ambient Temperature	0 ~ +60℃
Weight	250 Kg

Hydronic Diagram

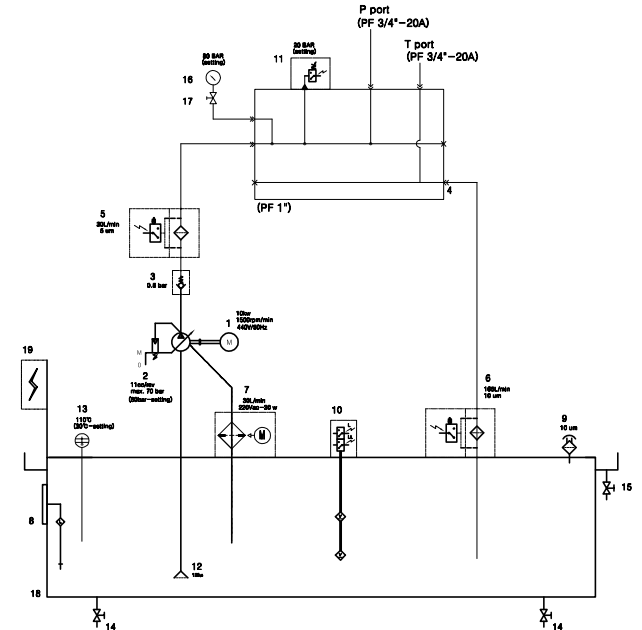

NO	ITEM	MAT'L	Q,TY	DIMENSION	REMARKS
DESIGN	CHECK	APPROVE	3D ANGLE	NAME OF ARTICLE	PR-HTS-2.2-4-8-100-F-N-M-S-440.50
H. Y. M.	-	-	SCALE 1 / 1		Servo Hyd'power Tank Unit
21.03.11	-	-			
 PORA ELECTRIC MACHINERY CO.,LTD.				DWG NO.	CPC for Steering Roll System